

1.5, 2, 2.5, 3, 3.5, 4, 5 & 6 Ton Industrial Grade Wall Mounted Air Conditioners

Unit Application

Bebco Model IX-WAC Industrial Grade Air Conditioners are designed as a top-of-the-line highly qualified solution to building climate control in severely corrosive or Hazardous (Classified) Areas. Beginning with components utilized on standard Bard Hi-Boy® Wall Mount Series® Brand Air Conditioners, Bebco fabricates this unit from the ground up, by a process that assures National Electrical Code Article 500 compliance, while instilling the highest possible level of quality available, and the most exemplary solution to HVAC in highly corrosive environments. Portions of the line also bear an Underwriter's Laboratories Listing.

Technical Description

Bebco Model IX Air Conditioners are self contained wall mounted units with all necessary components to supply a room or building with recirculated air that is filtered, temperature controlled and humidity limited. The units consist of two isolated sections, stacked one atop the other. The lower section, known as the condenser compartment contains the condenser coil, the condenser coil motor, fan and shroud assembly, the compressor, and related sensors which supply the unit controls with signals to activate and deactivate the compressor and condenser fan. The upper section, known as the evaporator compartment, contains the evaporator coil, auxiliary heater elements (if supplied), and the evaporator blower assembly, which consists of two blower wheel fans and a dual shaft motor. In addition, the evaporator compartment contains the unit's electrical controls and a return air filter element. The units are contained within a 14 gauge seal-welded 316 grade stainless steel sheet metal housing that features wall surface mounting flanges, 18 gauge stainless steel ventilation grills on the condenser compartment, a drip shield flange, and an insulated panel cover that allow full access to the evaporator compartment. The units are intended for use in outdoor locations and feature a white enamel or custom paint finish, inside and out. Model IX-WAC units are intended for installation in areas where exposure to a severely corrosive atmosphere is either constant or very frequent. On the rear side of the units, a supply duct outlet (top) and return duct inlet (bottom) extend from the rear wall of the evaporator compartment. Upon installation, the ducts penetrate exterior building or room wall cutouts to recirculate air within the structure. The units are furnished with a drip shield and a bottom mounting flange, return grill, supply grill, filter and gaskets are shipped loose to complete installation. In addition, custom-built sectional supply ducting and supply registers can be furnished upon request to distribute air evenly to multiple rooms or across the length of a large area.

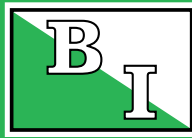

MODEL IX-WAC AIR CONDITIONERS

FOR HAZARDOUS & HIGHLY CORROSIVE AREAS

ECU Division Technical Bulletin IX-WAC-R1.0

05/04



Model IX-WAC-15-A-22-0



File Numbers
AINU.E183596
AINU7.E183596

Model IX-WAC G2 & 22 Units

File Numbers
XBDV.E184094
XBDV7.E184094

Model PT-AC Thermostats

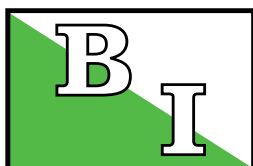

Bebco Industries

Environmental Control Units Division

4725 Lawndale
La Marque, TX 77568
PHN: (409) 935-5743
FAX: (409) 938-4189

Manufacturing Process

Starting with fully inspected and operationally tested components, Bebcu begins the manufacturing process within the seal-welded 316 stainless steel housing manufactured by Bebcu, by applying 1" polyisocyanurate insulation to all interior surfaces of the upper compartment and it's rear door. Then, a evaporator coil is installed in the upper compartment and a compressor is installed along with a condenser coil in the lower compartment. Technicians then install all necessary copper tubing with hand fitted solder joints to compete all interconnections between the condenser coil, the compressor and the evaporator coil and perform leakage tests. Upon proving the performance of all tubing, the condenser fan motor and fan blade are installed in the lower compartment. Finally, the unit is fitted with the evaporator blower motor and fan assembly, the units' electrical controls enclosure and all interconnecting wiring, prior to a complete performance test of the unit.

Component Ratings

On units for buildings or rooms with a nonrated interior atmosphere, a general purpose blower motor, a blower assembly with galvanized blower wheels, and a NEMA 4 rated electrical control enclosure are used in the evaporator compartment. On units for buildings or rooms with a Hazardous (Classified) interior, a Division 2 UL Listed TENV blower motor with hermetically sealed thermal overloads, a blower assembly with spark free-aluminum blower wheels and a NEMA 4 and 7 rated explosion proof electrical control enclosure are used.

On units for buildings or rooms located in a nonrated (General Purpose) area, a standard compressor, general purpose fan motor, and galvanized fan blade are used in the condenser compartment. On units for buildings or rooms located in a Hazardous (Classified) area, a modified compressor, Division 2 UL Listed TENV fan motor, and spark-free aluminum fan blade are used.

On all units, sealed flex conduit, appropriate conduit seals, form seven fittings and wiring are installed in the condenser compartment for interconnection wiring between the compressor, condenser motor and the unit's electrical controls. The evaporator compartment is fitted with a sealed wiring harnesses or seal-flex conduit and conduit seals, depending on the rating of the building or room's interior as noted above.

In, addition an intrinsically safe repeater relay is added to protect the thermostat for buildings or rooms with Hazardous (Classified) interiors and intrinsically safe barriers are added for all condenser compartment sensors on units for buildings or rooms located in a Hazardous (Classified) areas

Finally, as required, a Type "Y" purging system is added to protect the evaporator blower motor, condenser fan motor and all associated conduit and junction boxes to render the electrical components in either or both compartments suitable for Class I, Division 1 or 2 Hazardous (Classified) Areas.

Special conduit is also added for reciprocating compressor crankcase heaters. High pressure or low ambient sensors are added on units featuring scroll compressors and on units exceeding 1.5 tons.

The addition of a Type "Y" purging system renders Units suitable for use in Class I, Division 1 & 2, Group B, C & D Hazardous (Classified) Areas..

Call Bebcu for availability of Zone Classified Units.

Unit Ratings Defined

The most distinguishing difference between various models within the Model IX-WAC Product Line, besides the obvious difference of size, is the classification of the evaporator and condenser compartments. As noted to the left, since the units are intended for use in a multiple combination of area ratings, the condenser compartment and evaporator compartment are considered separately. This is because while the condenser compartment is exposed to the atmosphere surrounding the climate controlled building or room, the evaporator compartment is only exposed to the air which is recirculated within the room or building, as illustrated to the right. For this reason, Bebcu designs units that are suitable for a combination of nonrated (General Purpose), Division 2 or Division 1 Areas either inside or outside of the building or room.

The units are distinguished by a segment of the Model Number that identifies the unit's electrical rating. The segment consists of two characters which represent, in sequence, the rating of the evaporator compartment and the condenser compartment - top and bottom respectively. The characters represent the following area ratings:

"G" represents "General Purpose"

"1" represents "Division 1"

"2" represents "Division 2"

To meet normally encountered scenarios, four variations, specifically "G2, 22, 21 and 11", are offered as standard products. Bebcu "G2 and 22" Units are UL Listed, while "21 and 11" Units, along with all custom variations, including "GG, G1, 2G, 1G and 12" units are non-listed.

To understand the sequence of characters, for example, a rating of "G2" represents a unit that is only suitable for a Nonhazardous Area within the room or building and suitable for a Division 2 Area on the exterior of the building or room. A rating of "22" represents a unit that is suitable for a Division 2 Area both inside and outside of the building or room. A rating of "21" represents a unit that is suitable for a Division 2 Area within the room or building and suitable for a Division 1 Area on the exterior of the building or room. As a last example, a rating of "11" represents a unit that is suitable for a Division 1 Area both inside and outside of the building or room.

Read these **IMPORTANT NOTES** for critical information regarding unit design

IMPORTANT "G2" UNIT NOTES

"G2" Units are designed and approved for use on control rooms or buildings classified as Nonhazardous as a result of Type Z pressurization in accordance with NFPA 496. In addition, the control rooms or buildings must contain no internal source of ignitable concentrations of gases or vapors, e.g. analyzer rooms.

"G2" Unit rear access covers do not have to be considered as an opening capable of being opened in the calculation for minimum outward velocity in accordance with NFPA 496 section 5-4.1(b), *Exception No. 2*.

"G2" Units must be connected to a power (service) disconnect switch behind a separate disconnect switch for the pressurization unit, in accordance with NFPA 496 section 5-4.9.

- also applies to non-UL rated "G1" Units -

Cross Sectional View

Recirculating Climate Control Unit

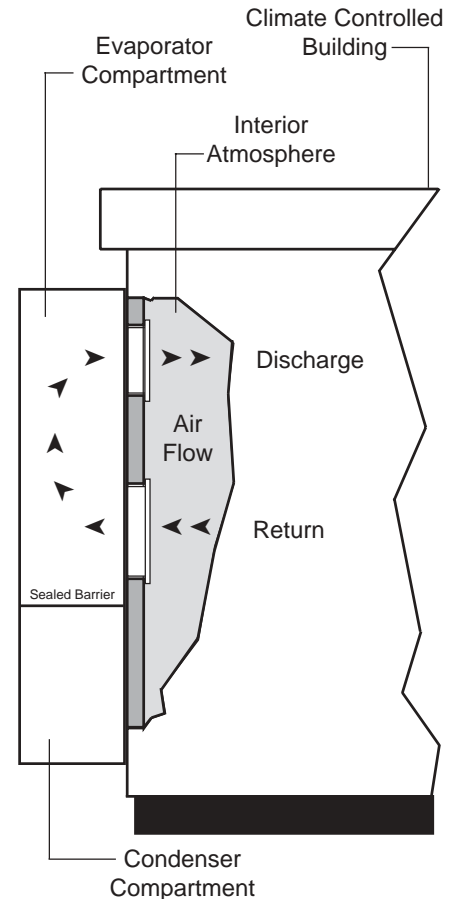

The surrounding atmosphere is circulated through this compartment to dissipate accumulated heat from the condenser coil

IMPORTANT "22" UNIT NOTES

"22" Units are designed and approved for use on control rooms or buildings classified as Class I, Division 2, Groups C&D and contain no internal source of ignitable concentrations of gases or vapors (applies primarily to analyzer rooms).

"22" Units are also designed and approved for use on analyzer rooms or buildings classified as Class I, Division 2, Groups C&D, if the room or building is ventilated in accordance with NFPA 496 section 7-2.6.

- also applies to non-UL rated "21" & "2G" Units -

IMPORTANT "11" & "21" NOTES

"11 and 21" as well as "1G, G1 and 12" Units incorporate a Type "Y" pneumatic purging system to render all or some Division 2 rated motors and conduit systems suitable for a Division 1 Group B, C & D Hazardous Areas.

User must provide a clean source of instrument air or inert gas that is essentially free of any ignitable concentration of combustible gas, and operate purging system in complete accordance with manufacturer's instructions and NFPA 496.

"1 & 2" Prefix Interior View

"G" Prefix Interior View

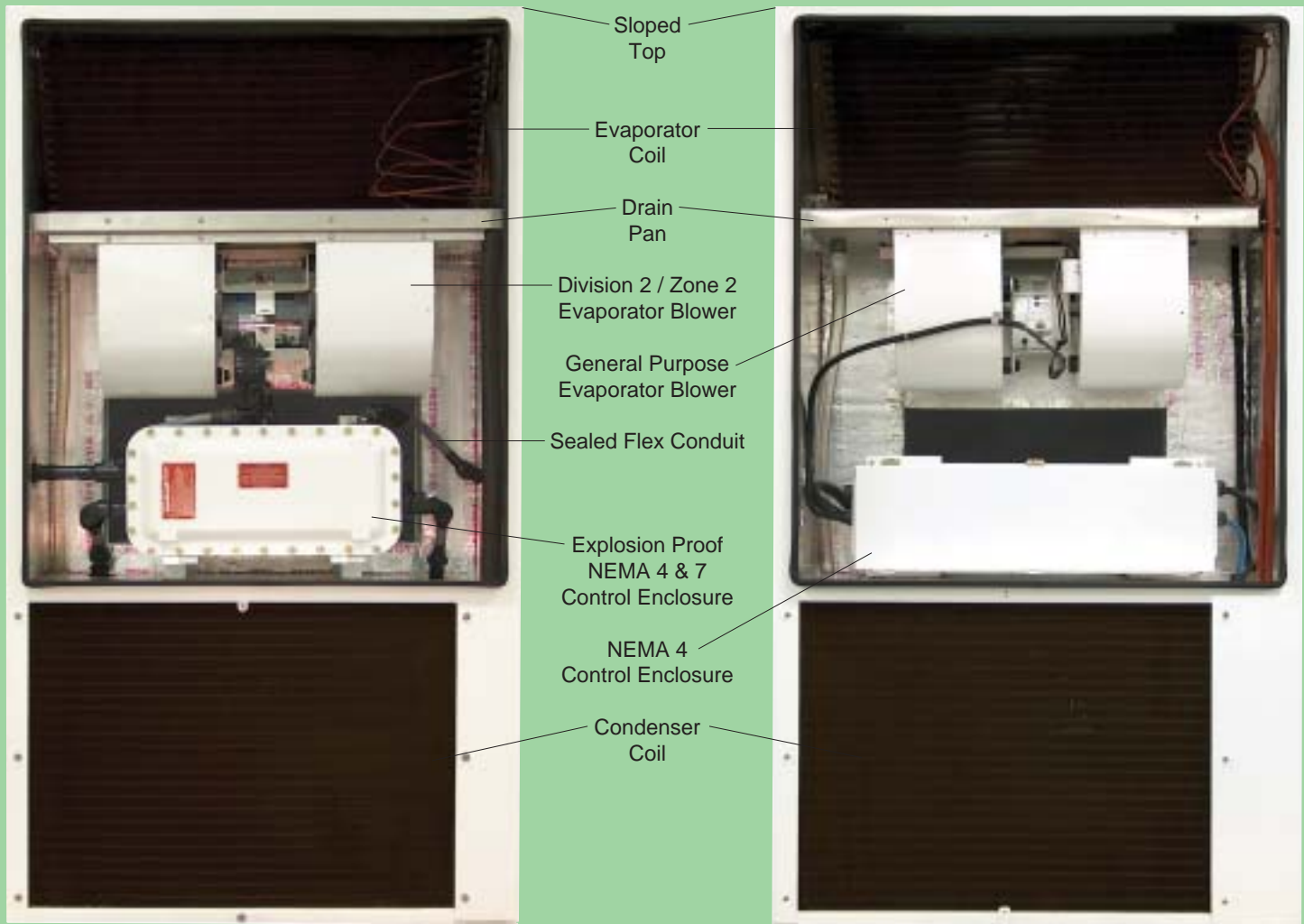

Term "Prefix" above and below refers to Unit's Electrical Rating

Typical "1 & 2" Prefix Controls

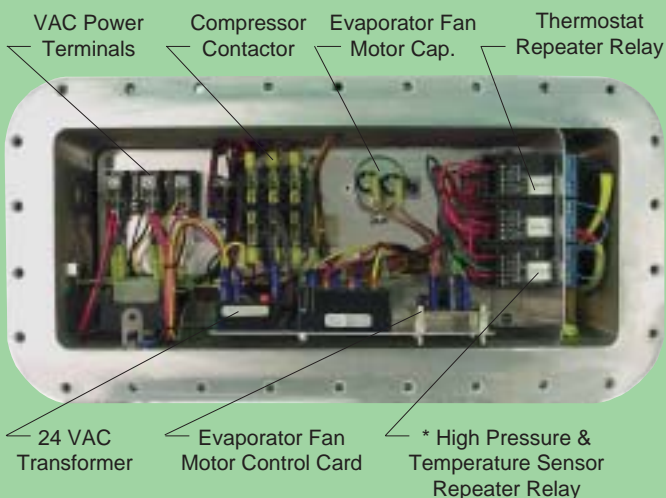

Typical "G" Prefix Controls

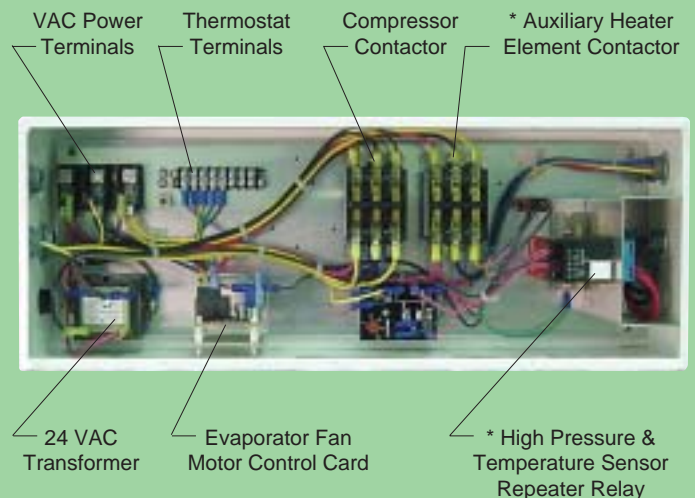

IMPORTANT NOTE

Items marked with an asterisk (*) above, may not be included on all units, dependent on compressor style furnished

Auxiliary Heater Wiring

Standard Connection Plate for Nonhazardous Areas



Inset Showing Cover Plate Installed

Auxiliary Heater Elements

For "G2" Units

Standard 5-20 Kilowatt Heater Elements for Nonhazardous Areas



For "22" Units

Finned Tube Heater Elements for Division 2 Areas

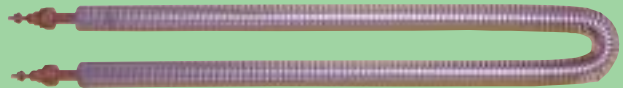

Compressor Assembly *

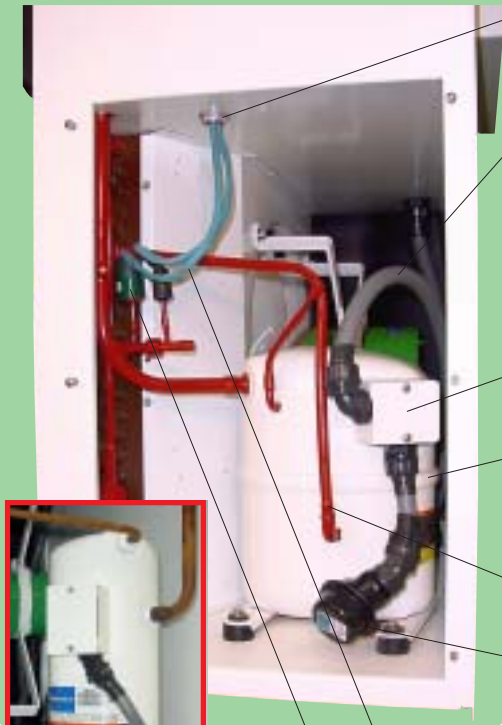

Scroll Compressor

Wiring Feed-Through Hub

Sealed Flex Conduit

Evaporator Drain Pan's Drain Tube

TENV Motor with Hermetically Sealed Thermal Overloads and Aluminum Fan Blade

Compressor Wiring Junction Box

Reciprocating* Compressor

Sealed Interconnection Wiring Junction Boxes

Heresite® Coating**

Crankcase Heater Access Fitting

Non-Incendive Wiring to High Pressure & Low Ambient Sensors

Pressure Sensor

Condenser Fan Assembly

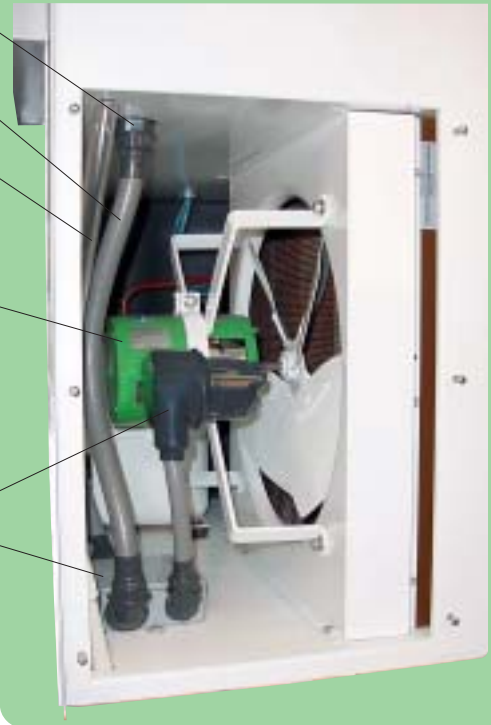

Compressor & Condenser Fan Assembly Photos above represent "1 & 2" Suffix Configurations

IMPORTANT NOTES

* Unit Compressors, as supplied by Bard Manufacturing may vary, as noted below.
 1.5 to 3.5 Ton Units may feature either Reciprocating or Scroll Style Compressors.
 4 to 6 Ton Units will feature Scroll Style Compressors only with High Temperature Sensors.
 All Reciprocating Style Compressors feature Crankcase Heater.

** All associated tubing along with the Condenser Coils and Evaporator Coils are Heresite® coated.
 Other coatings are available upon request - please contact BebcO for more information.

Heresite® is a registered trademark of Heresite Protective Coatings, Incorporated

Basic Unit Wiring Requirements & Compatible Accessories

Bebco HVAC Units

Model IX-WAC "GG, G1 & G2" Units

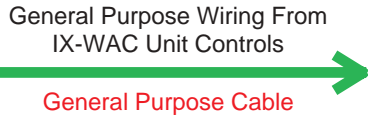

Unit Accessories

Model PT-AC-GM



U.L. Listed Manual Thermostat for General Purpose Areas

Model PT-AC-GA



U.L. Listed Automatic Thermostat for General Purpose Areas

Coiled Wire Heater Elements



Internally Mounted & Pre-Wired
 See Page 8 for Available KW Ratings

Model IX-WAC "2G, 22 & 21" Units

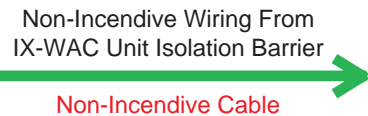

Model PT-AC-HM



U.L. Listed Manual Thermostat for Division 2 Areas

Model PT-AC-HA



U.L. Listed Automatic Thermostat for Division 2 Areas

Finned Tube Heater Elements



Internally Mounted & Pre-Wired
 See Page 8 for Available KW Ratings

Model IX-WAC "1G, 12 & 11" Units

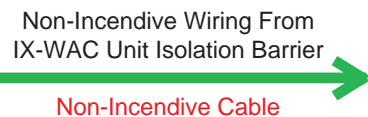

Model MT-AC-HM



U.L. Listed Manual Thermostat for Division 1 Areas

Finned Tube Heater Elements



Internally Mounted & Pre-Wired
 See Page 8 for Available KW Ratings

Unit Specifications

Overall Dimensions:	see page 7
Shipping Weights (lbs):	1.5 & 2.0 Ton Units 350
	2.5 & 3.0 Ton Units 435
	3.5, 4.0, 5.0 & 6.0 Ton Units 560
Operating Temp Ranges:	-40° F - 104° F
Power Wiring Conduit Entries:	3/4" FPT
Thermostat Wiring Conduit Entries:	1/2" FPT
T- Code Rating	T3
Operating Voltages:	208/230 VAC 1Ø 60 Hz
	* 208/230 VAC 3Ø 60 Hz
	** 460/480 VAC 3Ø 60 Hz
	*** 208 VAC 3Ø 50 Hz
	*** 415 VAC 3Ø 50 Hz

- * Voltage not available for 1.5 ton Units
- ** Voltage not available for 1.5 or 2.0 ton Units
- *** Voltage for European Applications - Not UL listed

Terms "Suffix" and "Prefix" below refer to Unit's Electrical Rating

Component Specifications

"G" Suffix Condenser Fan Motor:	General Purpose
"1 & 2" Suffix Cond. Fan Motor:	TENV Div. 2, C&D
"G" Prefix Evaporator Blower Motor:	General Purpose
"1 & 2" Prefix Evp. Blower Motor:	TENV Div. 2, C&D
Compressor Type:	* Scroll or Reciprocating
"G" Prefix Control Enclosure:	NEMA 4
"1 & 2" Prefix Control Enclosure:	NEMA 4 & 7

- * Furnished compressor type may vary from unit to unit

Material Specifications

Unit Housing & Door:	Painted 14 ga. 316 Stainless Steel
Ventilation Grills:	Painted 18 ga. 316 Stainless Steel
Access Door Fasteners:	Cast Zinc Body / Zinc Bolt
Evaporator Coil:	Heresite® Coated Copper & Alum.
Evaporator Blower Motor:	Painted Carbon Steel Housing
"G" Prefix Blower Wheels:	Painted Galv. Steel
"1 & 2" Prefix Blower Wheels:	Painted 3003 gd. Alum.
Compressor Body:	Painted Carbon Steel
Condenser Fan Motor:	Painted Carbon Steel Housing
Condenser Fan Blade:	Painted 3003 gd. Aluminum
Condenser Coil:	Heresite® Coated Copper & Alum.
Unit & Device Nameplates:	Silkscreened Lexan®
Model Number Nameplate:	Silkscreened 316 SS
"G" Prefix Control Enclosure:	Painted 14 ga. 316 SS
"1 & 2" Prefix Control Enclosure:	Painted Cast Aluminum
Electrical Conduit & Fittings:	Plasti-Bond REDH ₂ OT® Coated Cast Zinc & Aluminum

Lexan® is a registered trademark of the General Electric Corporation
 Heresite® is a registered trademark of Heresite Protective Coatings, Inc.
 Plasti-Bond REDH₂OT® is a registered trademark of Robroy Industries, Inc.

Housing Finish Specifications

Standard Finish:	1 mil Wash Primer & (BEBCO)
	3 mil White Urethane coating on exterior housing surface and all exposed interior metal brackets, parts and components

Custom Finish: per written customer specification (USER)

Unit Minimum Circuit Ampacity Chart

Unit Tons	208 VAC/1Ø						208 VAC/3Ø						460 VAC/3Ø			
	Aux. Heat Kw						Aux. Heat Kw						Aux. Heat Kw			
	0	5	8	10	15	20	0	6	9	15	18	0	6	9	15	
1.5	16	30	45	56	-	-	-	-	-	-	-	-	-	-	-	
2.0	17	30	45	56	-	-	13	22	-	-	-	-	-	-	-	
2.5	24	31	47	57	83	-	17	23	32	50	-	10	12	17	26	
3.0	27	31	47	57	83	-	20	23	32	50	-	10	12	17	26	
3.5	33	33	-	59	85	110	24	-	34	52	60	12	-	17	26	
4.0	38	38	-	59	85	110	26	-	34	52	60	13	-	17	26	
5.0	44	44	-	59	85	110	32	-	34	52	60	16	-	17	26	

Important "G2" & "G1" Installation Notes

A minimum outward velocity of 0.305 m/sec (60 fpm) is required when the Rear Access Door is removed in accordance with par. 5-4.1(b) of the NFPA 496 1998 edition. However, exception No. 2, excluding Gland, Bulkhead or Similar Covers that require a tool or key for removal may be used to exclude this opening from calculations to determine total air flow capability of a pressurization unit utilized to protect the building.

DO NOT install any damper, air filtration unit or similar equipment in the duct connected to this climate control unit which may restrict the positive pressure air system.

Unit Mounting & Wall Cut Out Template

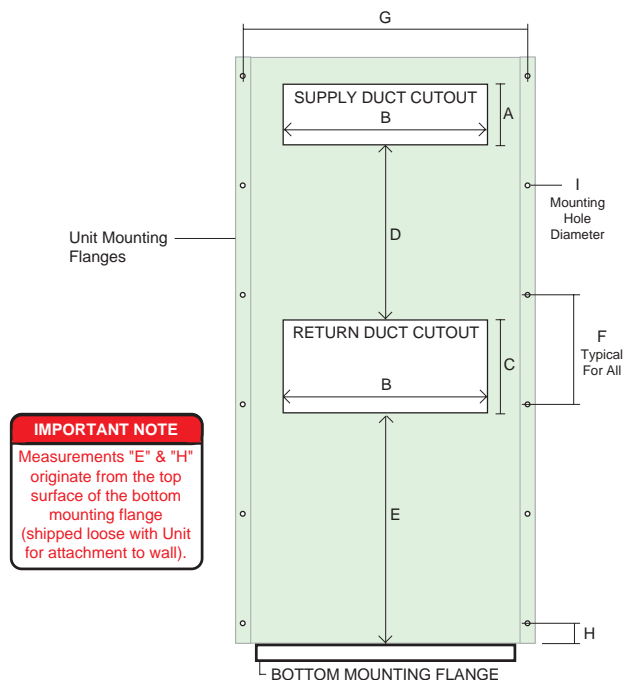

IMPORTANT NOTE
 Measurements "E" & "H" originate from the top surface of the bottom mounting flange (shipped loose with Unit for attachment to wall).

Template Dimensions by Tonnage Size

TONS	A	B	C	D	E	F	G	H	I
1.5 & 2.0	8.125	20.125	12.125	20.5	29	12	36.625	6.75	0.375
2.5 & 3.0	8.125	28.125	14.125	17.75	28.75	12	41.5	6.875	0.375
3.5	10.125	30.125	16.125	29.75	27.75	16	45.875	2.5	0.375
4.0									
5.0									
6.0									

All Dimensions shown in inches. Cutout Clearance is 0.125"

Model IX-WAC "GG, G2 & G1" Units

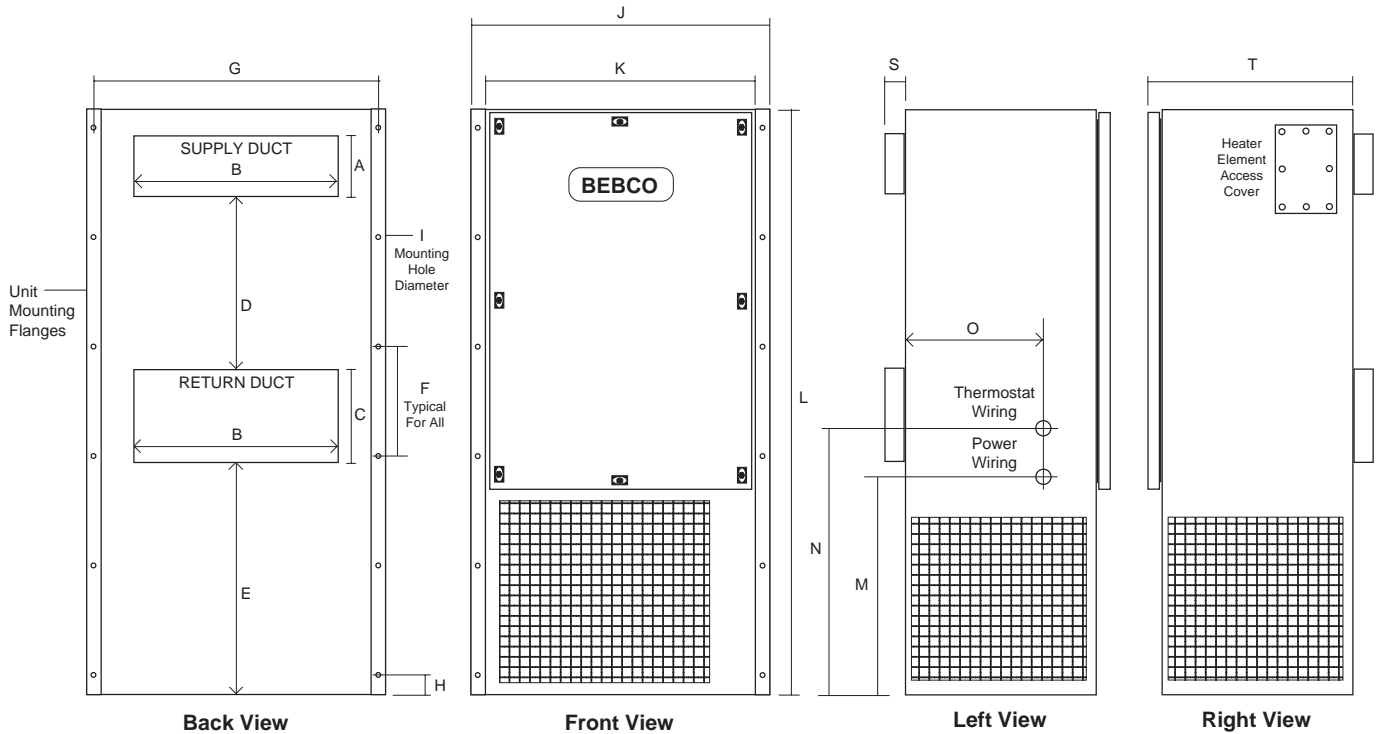

Model IX-WAC "2G, 22, 21, 1G, 12 & 11" Units

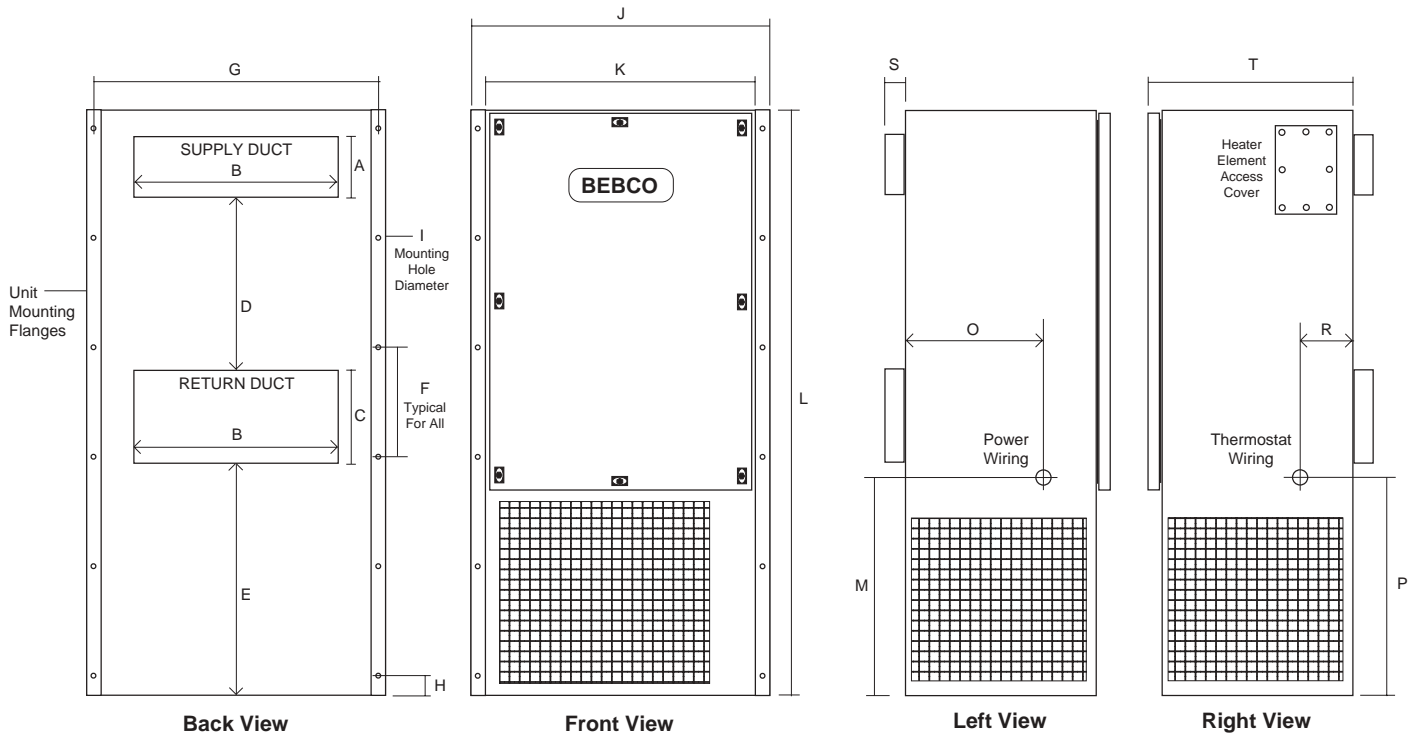

Unit Dimensions by Tonnage Size

TONS	A	B	C	D	E	F	G	H	I	J	K	L	M	N	O	P	R	S	T
1.5 & 2.0	7.875	19.875	11.875	20.75	29.125	12	36.625	6.75	0.375	38.25	34.875	72.625	31.25	35.25	12.5	31.25	4.875	1.5	20.75
2.5 & 3.0	7.875	27.875	13.875	18	28.875	12	41.5	6.875	0.375	43	39.875	72.75	35.5	35.25	10.5	35.25	5.75	1.5	20.75
3.5 4.0 5.0 6.0	9.875	29.875	15.875	30	27.875	16	45.875	2.5	0.375	47.5	44.25	84.875	41.25	41.25	16.75	45.75	11.875	1.5	25.375

All Dimensions shown in inches. All Dimensions are shown for reference purposes only and subject to change without notice.

Coiled Wire Heater Elements

"GG, G2 & G1" Rated Units Only

UNIT TONS	----- 60 Hz UNIT VOLTAGES -----		
	- A -	- B -	- C -
	1Ø 208/230 VAC	3Ø 208/230 VAC	3Ø 460 VAC
1.5	AC15AG2H05 ? AC15AG2H08 AC15AG2H10	Last Two Digits "05" = Kilowatts	
2	AC20AG2H05 AC20AG2H08 AC20AG2H10	AC20BG2H06	
2.5	AC25AG2H05 AC25AG2H08 AC25AG2H10 AC25AG2H15	AC25BG2H06 AC25BG2H09 AC25BG2H15	AC25CG2H06 AC25CG2H09 AC25CG2H15
3	AC30AG2H05 AC30AG2H08 AC30AG2H10 AC30AG2H15	AC30BG2H06 AC30BG2H09 AC30BG2H15	AC30CG2H06 AC30CG2H09 AC30CG2H15
3.5	AC35AG2H05 AC35AG2H10 AC35AG2H15 AC35AG2H20	AC35BG2H09 AC35BG2H15 AC35BG2H18	AC35CG2H09 AC35CG2H15
4	AC40AG2H05 AC40AG2H10 AC40AG2H15 AC40AG2H20	AC40BG2H09 AC40BG2H15 AC40BG2H18	AC40CG2H09 AC40CG2H15
5	AC50AG2H05 AC50AG2H10 AC50AG2H15 AC50AG2H20	AC50BG2H09 AC50BG2H15 AC50BG2H18	AC50CG2H09 AC50CG2H15

Model Number Designations

Typical Model: **IX - WAC - 15 - A - G2 - 0**

Model **IX** - Industrial Grade

Style **WAC** - Wall Mount
Air Conditioner

Tonnage		BTU Rating*
15	- 1.5 Tons	18300
20	- 2.0 Tons	24000
25	- 2.5 Tons	31000
30	- 3.0 Tons	36000
35	- 3.5 Tons	43000
40	- 4.0 Tons	47500
50	- 5.0 Tons	57500
60	- 6.0 Tons	68000

Voltage **A** - Single Phase 208/230 VAC 60 Hz
B** - Three Phase 208/230 VAC 60 Hz
C*** - Three Phase 460 VAC 60 Hz
D - Three Phase 208 VAC 50 Hz
E - Three Phase 415 VAC 50 Hz

Class I Electrical Rating

	Interior	Exterior
G2	- Nonhazardous	Division 2
22	- Division 2	Division 2
21	- Division 2	Division 1
11	- Division 1	Division 1

(see below for additional electrical ratings)

Paint Finish

0	- Standard Finish
1	- White Urethane Finish
2	- Custom Finish

UL Listed Standard Model Selection Notes:

- * BTU rating @ 75° F outside ambient - Units operating at or below 65° F outside ambient require low ambient control accessory
- ** Voltage not available for 1.5 ton Unit
- *** Voltage not available for 1.5 or 2.0 ton Units

Non-UL Listed Special Order Model Selection Notes:

Voltages "D" & "E" above - 50 Hz - available by special order
 G1, 2G, 21, 1G, 12 & 11 Rated Units feature purged components
 GG, G1, 2G, 21, 1G, 12, & 11 Rated Units available by special order
 Class II & Zone 1 & 2 Rated Units available by special order
For more information and availability, please contact BebcO

Local Sales Representative

KGA Engineering Company, Inc.
Bebco Midwest Representative
 847.367.5700
www.kgaeng.com

Finned Tube Heater Elements

"2G, 21, 22, 1G, 12 & 11" Rated Units Only

UNIT TONS	----- 60 Hz UNIT VOLTAGES -----		
	- A -	- B -	- C -
	1Ø 208/230 VAC	3Ø 208/230 VAC	3Ø 460 VAC
1.5-3	AF30A22H03	AF30B22H03	
3.5-6	AF60A22H05	AF60B22H05	AF60C22H05

Heater Element Notes:

Finned Tube Heater Elements voids UL Listing on Units.

For 50 Hz Unit Voltages, please consult factory sales agent.

For isolated radiant heater units, refer to the Remote Heater Unit Specification Bulletin.

For information regarding duct mounted heating units and auxiliary forced air heating units, please contact factory sales agent.

Unit Thermostats

Model Number	Intended Units	U.L. Rating
PT-AC-GM	"GG, G2 & G1" Units	General Purpose
PT-AC-GA	"GG, G2 & G1" Units	General Purpose
PT-AC-HM	"2G, 22" & "21" Units	C1, D2, Gr. C & D
PT-AC-HA	"2G, 22 & 21" Units	C1, D2, Gr. C & D
MT-AC-HM	"1G, 12" & "11" Units	C1, D1, Gr. C & D

Notes: Thermostats with a "M" Suffix are manually operated and non-programmable. Thermostats with an "A" suffix are programmable with automatic switch-over between Heating and Cooling Modes.

IMPORTANT NOTES

All specifications subject to change without notice.
 Warranty & Liability policies available upon request.