

Shelter Application

Bebco Industrial Duty Fiberglass Shelters are intended for chemical processing or waste water treatment areas where corrosive vapors such as hydrogen sulfide or chlorine are present and offshore or costal areas where salt-laden air or saltwater spray is prevalent. Beyond corrosion resistance, the coating materials utilized includes a glass fiber reinforced Class 1 flame-retardant resin and a UV resistance gel coating that is available in a variety of colors.

Construction Method

Bebco Industrial Duty Fiberglass Shelters are utilized with Bebco Shelter Bases and Doors to form a complete industrial duty fiberglass building. Options such as windows, interior and exterior lighting systems and other accessories may be added upon request. The Shelters are provided in a Standard or Deluxe Grade that differ in outward appearance, but share many similar construction features. Both Grades feature individual wall and roof sections, formed separately within an 18 gauge galvanized sheet metal frame. The frame consists of a perimeter "U" shaped channel and ribs, positioned vertically on two foot maximum centers, formed from two "U" shaped channels fitted back to back. The ribs of the roof and adjacent wall sections align, and the space within each section is filled with polyisocyanurate insulation sheeting. Prior to erection, all sections are spray coated with a glass fiber and resin composite mixture on both sides to form an initial Class A flame-retardant coating. The Deluxe Grade then receives body filler and an additional resin coating on both sides. When fully cured, the wall sections are lifted into place and bolt fastened to an angle iron frame that is welded to a Bebco Shelter Base. The perimeter frame members of all walls are then screwed together. To complete assembly, the roof section is lifted into place and screw fastened to the top perimeter frame member of the walls. To finalize construction, both Grades receive an exterior surface coating of glass fiber and resin to form a sealed, monolithic structure. A 6 mil gel coating is then roller applied inside and out to attain a smooth, UV resistant finish.

Bebco Industrial Duty Fiberglass Shelters are also available in two distinct lifting configurations. The Bottom Lift Configuration is manufactured as noted above and is suitable for bottom point lifting by provisions incorporated in the Bebco Shelter Base. The Top Lift Configuration is achieved by exclusion of the angle iron frame noted above and inclusion of a tubular steel frame that surrounds each wall section, along with permanently attached lifting eyes, positioned as required for balanced weight load distribution. In the Top Configuration, the tubular frames of each wall section are welded together and (if included) to a Bebco Shelter Base, to permit top point lifting of the complete structure. See Technical Specifications, starting at Page 2, for complete Shelter construction details.

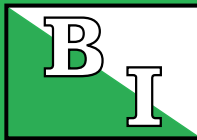

INDUSTRIAL DUTY FIBERGLASS SHELTERS

FOR HIGHLY CORROSIVE & MARINE LOCATIONS

ISD Technical Bulletin IDFS-R1.1

07/04



Deluxe Grade



Standard Grade

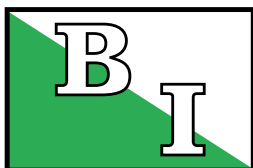

Bebco Industries

Industrial Shelters Division

4725 Lawndale
La Marque, TX 77568
PHN: (409) 935-5743
FAX: (409) 938-4189

Technical Specifications

1.0 - Fabrication Materials:

Bebco Industrial Grade Fiberglass Shelters shall be fabricated from materials which meet or exceed the following specifications:

1.1 - Wall & Roof Section Framing: Perimeter and rib frame members of each individual wall section and the roof section shall be formed from 18 gauge galvanized steel sheet metal, which has been machine cut and bent to form C shape channels of various widths and depths as specified below.

1.2 - Base Angle Framing: The base angle provided to attach individual wall sections to a Bebco Open, Grated, Sump or Deck Style Base shall be formed from ASTM A-36 forged angle iron beam with a minimum profile of 3" x 3" x 1/4", a minimum tensile strength of 36,000 PSI and a minimum yield strength of 58,000 PSI.

1.3 - Top Lift Configuration Framing: Tubular Steel shall be utilized as a structural frame surrounding each wall section of Top Lift Configuration Shelters, formed from ASTM A-500 Grade C forged beams with a minimum profile of 3" x 3" x 1/4"W, a minimum tensile strength of 58,000 PSI and a minimum yield strength of 39,000 PSI.

1.4 - Panel Insulation: All individual wall and roof section frames shall be filled with Dow Chemical Trymer® Brand 2000-I Rigid Polyisocyanurate sheeting material, in individual or laminated forms, ranging from 3" thick to 12" thick. Minimum properties shall include a compressive strength of 25.0 lb/in², a density of 2.05 lb/ft³, and an R-Value of 5.3/inch @ 75°F, in accordance with ASTM Test Methods D1621, D1622 and C1303.

1.5 - Resin & Gel Coating Materials: Shelter coatings shall be formed with Reichhold, Incorporated DION FR® 7767 Flame-Retardant Resin and HK Research Corporation WHITE HydroShield® Light LHM-2900 LOW HAP NPG/ISO (100% NPG-Isophthalic) Marine Grade UV Resistant Gel Coating materials. Mechanical properties shall meet or exceed the following values:

Bebco Industrial Duty Fiberglass Shelter Coatings Properties			
Property	ASTM Test	Resin	Gel Coating
Tensile Strength @ 77°F:	D-638	8,000 psi	11,600 psi
Tensile Modulus @ 77°F:	D-638	540,000 psi	547,000 psi
Tensile Elongation @ 77°F:	D-638	1.6%	3.8%
Flexural Strength @ 77°F:	D-790	14,200 psi	18,450 psi
Flexural Modulus @ 77°F:	D-790	540,000 psi	545,000 psi
Barcol Hardness @ 77°F:	D-2583	48	35
Heat Distortion:	D-648	172°F	174 °F

1.6 - Coating Reinforcement & Matting: Coating reinforcement shall consist of Type E gun roving (chop-sprayed) random glass fibers from 1" to 1.5" in length. Coating over Standard Grade Structure frame members shall be reinforced with 0.022" thick BTI Type CM-2415 stitch fiber matting, at widths ranging from 3" to 6", as required.

1.7 - Bolt Fasteners: Fasteners that secure wall sections to the base angle shall be 3/8" diameter SAE Grade 5 zinc plated steel hex head bolts, with a proof load of 85,000 PSI and a minimum tensile strength of 120,000 PSI, ranging from 4" to 16" long, as required. Bolts shall be attached with zinc plated steel flat washers, lock washers and hex nuts.

1.8 - Screw Fasteners: Fasteners that secure adjacent wall and roof section perimeter and rib frame members shall be Olympic Fastener Extra Heavy Duty Screws, with a #3 Phillips truss head diameter of 0.435", a thread diameter of 0.275" and an Olympic CR-10 corrosion resistant coating per FM Standard 4470, ranging from 4" to 16" long, as required.

2.0 - Section Framing Fabrication & Insulation:

Bebco Fiberglass Wall & Roof Section Framing shall be fabricated in accordance with the following specifications:

2.1 - Wall & Roof Section Frame Forming: Framing members shall be precision cut and formed by CNC machinery to achieve a minimum flange profile of 1.5" O.D. with a web profile of 3" to 12" I.D., as required. Tolerance for machining shall be maintained at a maximum variance of ±0.05".

2.2 - Framing Member Preparation: After forming by CNC machinery, all wall and roof section frame members shall be prepared for assembly to remove all scale, surface oxidation, grease, oils and other surface contaminants, for the purpose of creating a surface profile suitable for the adhesion of the primary resin and glass fiber coating.

Trymer® is a registered trademark of Dow Chemical Company
 DION FR® 7767 is a registered trademark of Reichhold, Incorporated
 HydroShield® is a registered trademark of HK Research Corporation

2.3 - Frame Fitting and Joining: Perimeter frame members shall be formed from one (1) "C" shape channel element, facing inward, while rib members shall be formed from two (2) channels facing back to back to form a "H" shape. Rib member channels shall be joined back to back by a skip mig welding process of one inch long beads on 12" centers, along both exterior surfaces of each formed channel. Perimeter frame members shall be fitted by means of corner notches in the flanges of the horizontal member, to provide an "L" shaped joining seam. Perimeter frame members shall be joined at each corner by a seam mig welding process on both exterior surfaces of the face and web flange. Rib frame members shall be fitted and joined to the perimeter frame at centers not to exceed twenty four (24) inches, by a seam mig weld process on both exterior surfaces of the flange. (see figure 2.3-1)

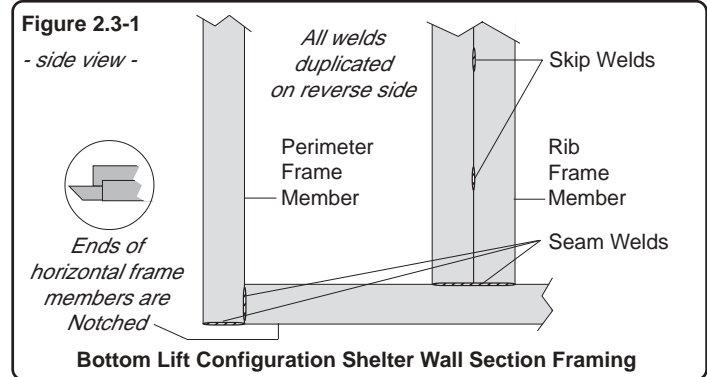

2.4 - Insulation Fitting: Insulation of specified thickness shall be fitted between the perimeter and rib frame members of each section, as the frame is assembled and welded. On Standard Grade Shelters, the insulation shall be inserted within the web flange of each channel that forms the perimeter and rib framing. (see figure 2.4-1) On Deluxe Grade Shelters, the web of all frame members shall be formed with an external dimension equal to the thickness of the insulation, and the edges of all insulation panels shall be beveled and fitted such that the exterior surface of the insulation and all frame members is flush. (see figure 2.4-2)

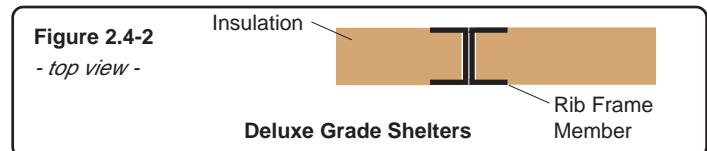
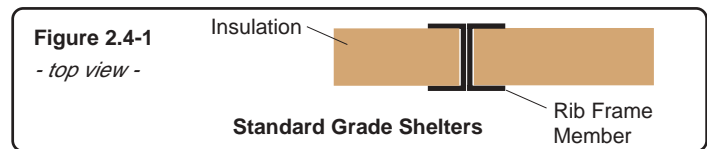

All wall & roof sections shall be formed individually, using metal framing & sheet insulation

2.5 - Roof Section Fabrication: Roof Sections shall be fabricated in accordance with all preceding specifications, with the following exceptions: Roof sections shall be fabricated in several distinct styles of gable and shed roof designs. With specific regard to Low Eave Gable, Low Flush Gable, Eave Shed and Flush Shed Styles, the perimeter and rib frame members shall be fabricated in a manner that forms a flat (or level) interior ceiling surface and a pitched (or angled) roof surface. The Insulation that fills the voids between the frame members shall be laminated and bevel cut, as

required, to fill the entire area. With specific regard to High Eave and Flush Gable Styles, three segments of standard perimeter and rib frame members and standard sheet insulation shall be utilized to form a triangular shell, with a cavity area that is void of insulation.

(see Standard Roof Style Applications)

2.6 - Top Lift Structural Frame Fabrication:

Top Lift Configuration Shelters shall be fitted with a tubular steel frame that envelopes the perimeter of all exterior wall sections. The tubular steel frame shall be formed from materials, as specified above, prepared in accordance with Specification 2.2, and shall be fitted and seal welded by a seam mig welding process. Wall sections shall then be fitted in the tubular steel frame and attached by a skip mig welding process of one inch long beads on 12" centers, along both exterior surfaces of each prefabricated wall section's perimeter frame. *(see figure 2.6-1)*

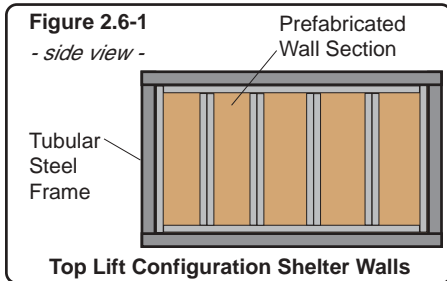

2.7 - Lifting Provisions: Top Lift Configuration Shelters shall feature four (4) to six (6) tubular steel extensions, in quantities and positions as required for balanced weight distribution, which shall extend from the tubular steel frame of opposing side walls (long sides of shelter) through the roof section's structure. The tubular steel extensions shall be capped by a steel plate of proportional thickness and incorporate a fixed position 316 grade stainless steel lifting eye bolt, rated as required, that is secured by a back-welded hex nut located under the cap of the extension. *(see figure 2.7-1)*

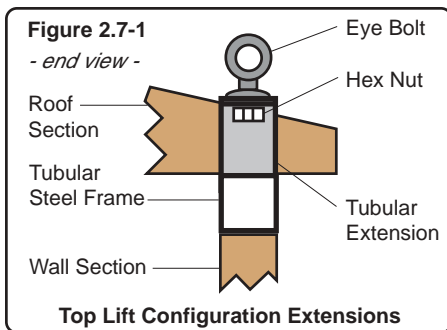

2.8 - Additional tubular steel frame members: Additional vertical tubular steel framing shall be utilized within perimeter wall sections, as required, to provide additional lifting support or structural integrity, particularly to wall sections exceeding a length of fourteen (14) feet. *(see figure 2.8-1)*

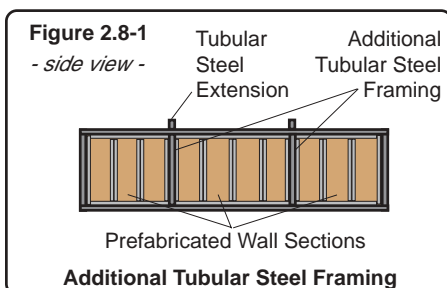

Fiberglass Shelter Roof Style Applications

Style LEG - Low Eave Gable:

For applications where climate is moderate to mild. Slope of one inch per foot (1/12) and a three inch (3") eave. Suitable for light snow and all levels of rainfall. Offers limited protection to exterior wall mounted equipment. Suitable for the addition of gutter and downspout trim. Suitable for Single and Double Wide Shelters.

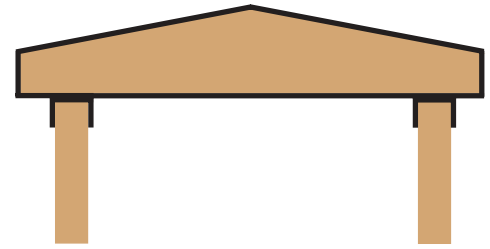

Style LFG - Low Flush Gable:

For applications where climate is moderate to mild. Slope of one inch per foot (1/12) with no eave. Suitable for light snow and all levels of rainfall. Offers no protection to exterior wall mounted equipment. Not intended for addition of gutter and downspout trim. Suitable for Single and Double Wide Shelters.

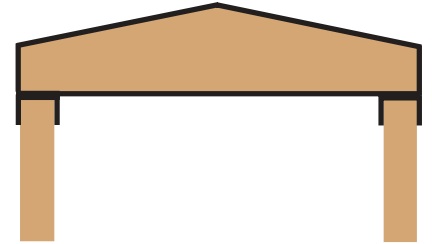

Style HEG - High Eave Gable:

For applications where climate is severe. Slope of 4 inches per foot (4/12) and a three inch (3") eave. Suitable for heavy snow and all levels of rainfall. Offers limited protection to exterior wall mounted equipment. Not intended for addition of gutter and downspout trim. Suitable for Single and Double Wide Shelters.

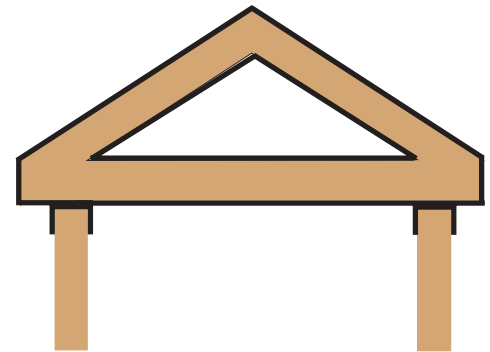

IMPORTANT NOTE:

Standard Eaves are four inches deep, but can be extended, as required, to provide additional protection for exterior wall mounted equipment.

Style HFG - High Flush Gable:

For applications where climate is severe. Slope of 4 inches per foot (4/12) and no eave. Suitable for heavy snow and all levels of rainfall. Offers no protection to exterior wall mounted equipment. Not intended for addition of gutter and downspout trim. Suitable for Single and Double Wide Shelters.

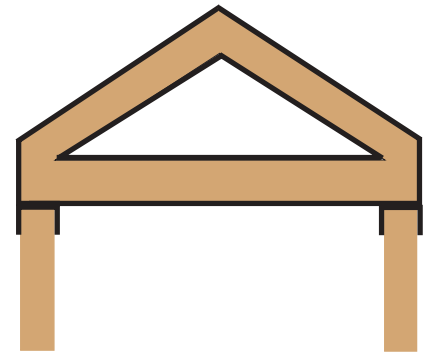

Style ES - Eave Shed:

For applications where climate is mild. Slope of one inch per foot (1/12) and a three inch (3") eave. Suitable for all levels of rainfall. Offers limited protection to exterior wall mounted equipment. Suitable for the addition of gutter and downspout trim. Suitable for Single Wide Shelters, not exceeding 14 feet.

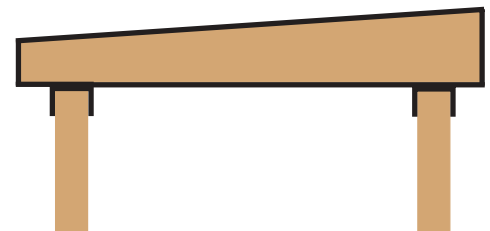

Style FS - Flush Shed:

For applications where climate is mild. Slope of one inch per foot (1/12) and no eave. Suitable for all levels of rainfall. Offers no protection to exterior wall mounted equipment. Not intended for addition of gutter and downspout trim. Suitable for Single Wide Shelters, not exceeding 14 feet.

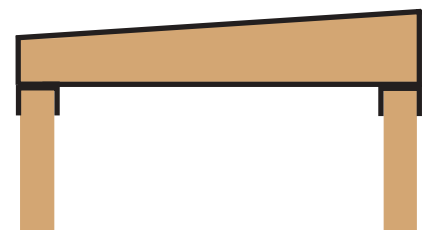

**Bebco Fiberglass Shelters are also available with flat roofs, as required
Please see Page 8 for more information**

3.0 - Initial Coating Applications:

Bebco Fiberglass Wall & Roof Sections shall receive an initial coating in accordance with the following specifications:

3.1 - Standard Grade Frame Matting: Prior to initial coating application, the interior and exterior surface of all wall and roof section frame members of Standard Grade Shelters shall be coated with resin and laminated with stitch fiber matting, as specified above, at widths ranging from 3" to 6", as required.

3.2 - Initial Coating Application: All wall and roof sections shall receive a preliminary spray coating of resin and gun roving (chop-sprayed) glass fibers on both sides, prior to erection. Material shall then be roller pressed to remove all trapped air and embed all fibers within the coating strata.

3.3 - Deluxe Grade Shelter Body Filler & Second Coating Applications: Following initial coating application, all wall and roof sections of Deluxe Grade Shelters shall receive an application of body filler and be lightly sanded, utilizing a combination of soft pad side grinders and orbital sanders to obtain a smooth finish, free of any visible blemishes or raised fibers. The interior surface of all wall and roof sections shall then receive a second spray coating of resin and glass fibers. Material shall then be roller pressed to remove all trapped air and embed all fibers within the coating strata. The interior surface shall then be lightly sanded, utilizing a combination of soft pad side grinders and orbital sanders to obtain a smooth finish, free of any visible blemishes or raised fibers.



An initial coating shall be applied to all wall & roof sections, prior to erection of the Shelter

4.0 - Shelter Wall & Roof Section Assembly:

Bebco Fiberglass Wall & Roof Sections shall be erected and secured in accordance with the following specifications:

4.1 - Bottom Lift Configuration Shelter Wall Erection: Assembly of Bottom Lift Configuration Shelters shall be initiated by the attachment of a base mounting angle to a Bebco Open, Grated, Sump or Deck Style Shelter Base. The angle shall be attached by a skip mig welding process, through 1/2" diameter fill-weld holes that are pre-punched through the bottom flange, along the entire length of the base mounting angle. Shelter walls shall then be lifted into position, plumbed and squared to the base. Each perimeter and rib frame member shall then be attached to the base angle, utilizing hex head mounting bolts, flat washers, lock washers and hex nuts, as specified above. (see figure 4.1-1)

Figure 4.1-1

- side view -

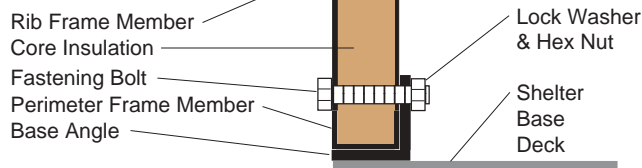

Bottom Lift Configuration Wall Section Attachment to Base Angle

4.2 - Top Lift Configuration Shelter Wall Erection: Assembly of Top Lift Configuration Shelters shall be initiated by lifting each wall section into place and then attaching the bottom frame member of each tubular steel frame to a Bebco Open, Grated, Sump or Deck Style Shelter Base, by a skip mig welding process of three inch long beads on 12" centers, along both sides of each frame.

4.3 - Bottom Lift Configuration Shelter Wall Section Joining: Adjacent wall sections of Bottom Lift Configuration Shelters shall be joined by screw fasteners placed on 12" centers, as specified above. Screws shall be threaded into the perimeter frame members of adjoining walls. (see figure 4.3-1)

Figure 4.3-1

- top view -

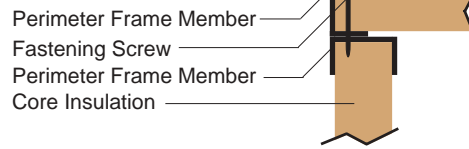

Bottom Lift Shelter Adjacent Wall Section Attachment

4.4 - Top Lift Configuration Shelter Wall Section Joining: Adjacent wall sections of Top Lift Configuration Shelters shall be joined by a skip mig welding process of one inch long beads on 12" centers, along both sides of each wall section's tubular steel frame.

4.5 - Roof Section Attachment: Roof sections of Bottom Lift Shelters shall be fastened by screws, as specified above, which pass through each perimeter and rib frame member of the roof section and thread into the top frame members of perpendicular (side) wall sections. End walls that are parallel to the roof section frame rib members shall be attached with screws on 12' centers. Roof sections of Top Lift Configuration Shelters shall be fitted over all tubular steel extensions, and shall be attached by a skip mig welding process of one inch long beads on 12" centers, along both sides of each wall section's tubular steel frame.



Bebco Shelters are assembled step, by step, from individual wall & roof sections, following an initial coating application

5.0 - Finish Coating Applications:

Assembled Bebcos Fiberglass Shelters shall receive a finish coating in accordance with the following specifications:

5.1 - Standard Grade Shelter Finish Coating Preparation: Following assembly of Standard Grade Shelters, the exterior surface shall receive a second spray coating of resin and glass fibers. Material shall then be roller pressed to remove all trapped air and embed all fibers within the coating strata. The exterior surface shall then be lightly sanded, utilizing a combination of soft pad side grinders and orbital sanders to obtain a smooth finish, free of any visible blemishes or raised fibers.



Assembled Shelters shall be body filled and sanded prior to application of the finish coating

5.2 - Deluxe Grade Shelter Finish Coating Preparation: Following assembly of Deluxe Grade Shelters, all exterior surfaces shall receive an application of body filler and be lightly sanded, as required, utilizing a combination of soft pad side grinders and orbital sanders to obtain a smooth finish, free of any visible blemishes or raised fibers. All exterior surfaces shall then receive a secondary spray coating of catalyst and resin based gel and gun roving (chop-sprayed) glass fibers. Material shall then be roller pressed to remove all trapped air and embed all fibers within the coating strata. The exterior surface shall then be lightly sanded, utilizing a combination of soft pad side grinders and orbital sanders to obtain a smooth finish, free of any visible blemishes or raised fibers.

5.3 - Shelter Gel Coating: Following Standard and Deluxe Grade Shelter Finish Coating Preparation, the adjacent wall and roof section seams of the interior and exterior surfaces shall be sealed, utilizing a hand-applied marine grade calking material. When all calking material is fully cured, the interior and exterior surfaces shall receive a roller applied 6 millimeter minimum white Gel Coating, to attain a smooth, UV resistant finish.

5.4 - Finished Coating Thickness: Finished Shelters shall receive a minimum finished thickness of applied resin, glass fiber and gel coatings in accordance with the following table:

Bebco Industrial Duty Fiberglass Shelter Minimum Applied Coatings

Standard Grade Interior Wall Resin & Fiber:	125 mils (1/8") ± 10%
Standard Grade Exterior Wall Resin & Fiber:	187 mils (3/16") ± 10%
Deluxe Grade Interior Wall Resin & Fiber:	187 mils (3/16") ± 10%
Deluxe Grade Exterior Wall Resin & Fiber:	187 mils (3/16") ± 10%
Interior & Exterior Surface Gel Coatings:	6 mils ± 10%

*Additional Resin, Glass Fiber and Gel Coating Thickness Available Upon Request
Resin, Glass Fiber & Gel Coating Material MSDS Available Upon Request*

6.0 - Special Provisions:

The following special provisions shall be applied, as required:

6.1 - Door, Cutout & Special Framing: All door and cutout openings shall be fitted with metal frame members with a minimum flange width of 1.5", to accommodate the attachment of door hinges and trim, cutout covers and equipment. Flange width of frames may be increased and spacing or location may be altered upon request, or to accommodate special design provisions.

6.2 - Double Wide Shelter Trussing & Roof Bracing: Shelter Roofs on double wide shelters shall incorporate truss members and shall be braced for shipment, dependent on the width and roof style selected.

6.3 - Double Wide Shelter Joining Seals: Bebcos shall supply sufficient materials and instructions, as required, to join and seal the seam of Double Wide Shelters.

6.4 - Materials of Construction: Wall and Roof Section Frame Members, Tubular Steel Framing, Base Angle and Fastener Materials shall be altered upon request to facilitate special design provisions, or to match Shelter Base Material.

Wall & Roof Section Composition

Standard Grade Wall & Roof Sections

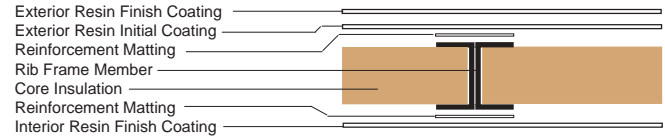

Deluxe Grade Wall & Roof Sections

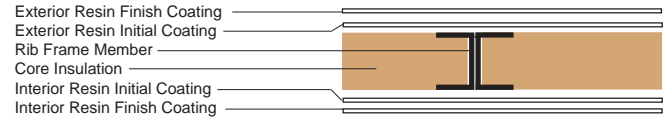

6 Mil Gel Coating Applied Over Interior & Exterior Finish Coatings Above



The finished Shelter shall be inspected carefully for compliance to all specifications prior to preparation for shipment

7.0 - Lifting & Loading Provisions:

All Bebcos Shelters shall be provided with lifting attachment points, to facilitate loading, transportation and placement.

7.1 - Bottom Lift Configuration Shelters: Bottom Lift Configuration Shelters shall require a Bebcos Shelter Base that shall be provided with detachable side mounted lifting tees or end mounted lifting extensions, to be sized dependent on Shelter weight load factors.

7.2 - Top Lift Configuration Shelters: Top Lift Configuration Shelters shall be supplied with or without a Bebcos Shelter Base, and shall be provided with non-removable lifting eye bolts that are sized dependent on Shelter weight load factors.



Bottom Lift Configuration Shelter Bases shall be equipped with Lifting Tees or end mounted Lifting Extensions



8.0 - Shelter Design Load Provisions:

All Bebcos Shelters shall meet or exceed the following load provisions:

Bebco Industrial Duty Shelter Design Load Provisions

Maximum Wind Speed:	120 MPH
Wind Exposure Level:	C
Maximum Roof Live (Snow*) Load:	70 Lbs/Sq Ft
Maximum Concentrated Roof Load:	250 Lbs
Maximum Temperature Range:	-40°F to 120°F
Seismic Zone Rating:	2 (UBC)

*Exposure Level "C" Defined As Flat Terrain With Scattered Obstructions
Snow Load Provision Applicable To High Eave & Flush Gable Roof Systems Only
Seismic Zone Rating per Uniform Building Code
Higher Design Load Provision Ratings Available Upon Request*

Standard Bebcos Shelter Sizes

Single Width Shelters					Single or Double Width Shelters							
06	08	10	12	14	16	18	20	22	24	26	28	
06x06	08x08	10x10	12x12	14x14	16x16	18x18	20x20	22x22	24x24	26x26	28x28	
06x08	08x10	10x12	12x14	14x16	16x18	18x20	20x22	22x24	24x26	26x28	28x30	
06x10	08x12	10x14	12x16	14x18	16x20	18x22	20x24	22x26	24x28	26x30	28x32	
06x12	08x14	10x16	12x18	14x20	16x22	18x24	20x26	22x28	24x30	26x32	28x34	
06x14	08x16	10x18	12x20	14x22	16x24	18x26	20x28	22x30	24x32	26x34	28x36	
06x16	08x18	10x20	12x22	14x24	16x26	18x28	20x30	22x32	24x34	26x36	28x38	
06x18	08x20	10x22	12x24	14x26	16x28	18x30	20x32	22x34	24x36	26x38	28x40	
	08x22	10x24	12x26	14x28	16x30	18x32	20x34	22x36	24x38	26x40	28x42	
	08x24	10x26	12x28	14x30	16x32	18x34	20x36	22x38	24x40	26x42	28x44	
		10x28	12x30	14x32	16x34	18x36	20x38	22x40	24x42	26x44	28x46	
		10x30	12x32	14x34	16x36	18x38	20x40	22x42	24x44	26x46	28x48	
			12x34	14x36	16x38	18x40	20x42	22x44	24x46	26x48	28x50	
			12x36	14x38	16x40	18x42	20x44	22x46	24x48	26x50		
				14x40	16x42	18x44	20x46	22x48	24x50			
				14x42	16x44	18x46	20x48	22x50				
					16x46	18x48	20x50					
					16x48	18x50						
					16x50							

Standard Bebcos Shelters are limited to a maximum width to length ratio of 1:3. Custom Shelters that exceed the minimum or maximum dimensions listed are available upon request.

Single Width Shelters that exceed a width of 14 feet require special permits and two (2) vehicle escorts.

Double Width Shelters disassembled after fabrication and shipped in two (2) sections. Most Double Width Shelters can be transported on one trailer, for site placement and reassembly.

Availability

- **Standard Shelters**
4-6 Weeks
- **Custom Shelters**
6-8 Weeks
- **Expedited Delivery ****
3-5 Weeks

All availabilities based on Bebcos receipt of Approved Construction Drawings and are dependant on openings in our existing work schedule.

** Subject to parts availability Charges will vary dependent on overtime requirements.

Quotations

- **Standard Shelters**
Client is required to utilize Bebcos Specifications.
Client must furnish placement diagram(s) to specify location of door(s) and cutout(s) in Shelter Walls & Roof. Quotation issued within one to three business days.
- **Custom Shelters**
Client must submit three (3) complete sets of specifications and drawings. Quotation issued within three business days.

Warranty

Bebco offers exemplary warranties against premature corrosion, finish degradation and defects in materials, parts and craftsmanship. Warranties cover all parts and labor required for repair, in the unlikely event of a confirmed failure.

Standard Term: 5 Years

This information is not intended to state or imply specific terms of any quotation and is presented strictly as a guideline for the buyer. Please refer to your particular quotation's terms for complete and detailed conditions of implied Bebcos Product Warranty.

Shipping

- **Bebco Site Delivery**
At your request Bebcos can coordinate and assume full responsibility for insurance, permits, escorts, loading, transportation and placement.



- **Client Pick-Up**
Clients can arrange all services, assuming full responsibility upon successful loading at Bebcos's facility.



Bebco can arrange and facilitate all aspects of Shelter loading, transportation, off-loading and site installation, upon request

Shelter Ordering Procedure

Forward:

In addition to a Model Number, the Client must furnish placement diagram(s) to specify location of door(s) and cutout(s) in Shelter Walls & Roof. Supplemental information, as illustrated herein, may also be furnished to specify the placement of other critical Shelter features.

IMPORTANT NOTE

Comments are presented along with the sample drawings to the right, as guidelines which should be carefully considered during the design process.

Shelter Ordering Example

Shelter Model Number: IDFS-D-08-10-20-T-03-LEG-02-06

In this example (as demonstrated on Page 8 of this document) the Client has specified a Bebcos Industrial Grade Fiberglass Shelter in a Deluxe Grade, with an 8 foot ceiling. The Shelter has exterior dimensions of 10 feet wide by 20 feet long and will be supplied in a Top Lift Configuration. The Shelter has walls which are 3 inches thick, with an R value of 15.9 and has a Low Eave Gable roof, that has a pitch ratio of 1:12 and a 3 inch eave span. Finally, the Shelter will feature 2 door openings and 6 wall cutouts.

As you will note in the drawings, the Client has shown a 3' Gable extension over the East wall, and requested gasketed 3003 aluminum bulkhead plates to cover the 4 cutouts on the West wall. These are the only tangible modifications to the Shelter specified by the Model Number above.

The Client has also noted that a Bebcos Model IX-WAC 3 Ton Air Conditioner Unit is to be installed on the South wall. This item will be listed as a separate line item on the purchase order.

In addition to the Shelter & AC Unit, the Client will be required to order two Bebcos Shelter Doors and will need to order one Bebcos Shelter Base or provide a concrete slab at the installation site for placement of the Shelter.

Beyond the additional items and required placement diagrams, the Shelter is completely specified by the model number above. All facets of construction are established by the specifications provided in this document.

(see important note below)

Sample drawings to the right are provided as an illustration of placement diagrams that are required to complete the Bebcos Shelter ordering procedure.

IMPORTANT NOTE

Although a significant degree of fabrication details are presented in this document, certain exclusions particularly related to specific engineering details regarding Gable Style roof system framing and Top Lift Configuration Shelter tubular steel framing have been omitted to protect proprietary engineering. These engineering details, primarily in the form of CAD Drawings, may be provided upon the placement of a purchase order, as a part of a certified engineering package, upon request.

COPYRIGHT PROTECTION RELEASE

This document is protected by Copyright © through registration with the United States Copyright Office - All Rights Reserved. Violation of copyright by unauthorized duplication or use of the text and illustrations contained herein by any competitor or by any party enured to or for the benefit or use by any competitor is therefore strictly prohibited. Violators will be prosecuted to the full extent of legal protection afforded under these federal rights.

Clients of Bebcos Industries, Incorporated are hereby released from said copyright protection. The specifications provided herein are available in Microsoft Word® Format for Client's use, and may be utilized in part or in totality, at our Client's discretion, for the purposes of establishing their own requirements or specifications for the construction of the items described herein.

Microsoft Word® is a Registered Trademark of the Microsoft Corporation

Client's Shelter Drawing Example

Note that all details specify directional side (N,S,E or W) and are labeled as Interior or Exterior views.

In the first drawing, the Client has elected to show gable extension on the East side of the Shelter, to protect external equipment. The detail is not necessary to Bebcos, because this feature could easily be specified in writing, but in this case it was a valuable element to help the client maintain perspective of the Shelter.

The notation of Flood Lights in the gable roof eaves alerted Bebcos to ensure that frame members would be located in this area to accommodate their attachment.

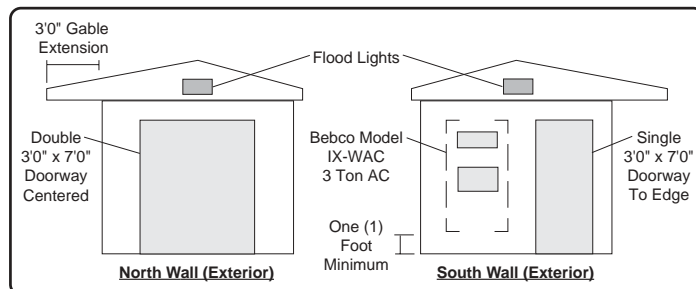

In the first drawing, 2 Doors, 2 Lights and 1 Air Conditioner Unit are shown. The double door notation is satisfactory, but the notation on the left detail to place the Single Door "to edge" must be considered. In this case, the 3 inch wall thickness plus 4 inches was necessary to provide sufficient clearance for the door frame, placing the doors right side 7 inches from the edge. Also note the Client selected a Bebcos AC Unit - otherwise, dimensions for the cutouts would be required.

The right detail indicates the AC Unit is to be mounted One (1) Foot, Minimum from the bottom on the Shelter, but since no horizontal position was specified, Bebcos was authorized to center the unit in the open area between the door frame and edge of the Shelter. Bebcos then determined the location of the cutouts.

In the drawing below, the Client has indicated the location of 4 cutouts, 3 light fixtures, 8 pieces of vertical mounting rail and 2 pieces of horizontal mounting rail. As you will note, the first detail is the West wall interior view, shown (in scaled perspective) slightly narrower than the detail of the East wall's exterior view. Consistent with good engineering practices, the vertical centerline of the cutouts and the horizontal centerline of each cutout and mounting rail are specified.

If you look closely, you can see that the dimensions on the West wall indicate four replicated sets of rails, on 18" centers, with a cutout located 12" to the left of each set at an elevation of 6 feet. In this particular case, the Client intends to mount 4 Gas Chromatographs on the wall and use the gasketed bulkhead plate covering the cutout adjacent to each Analyzer as a process tubing portal.

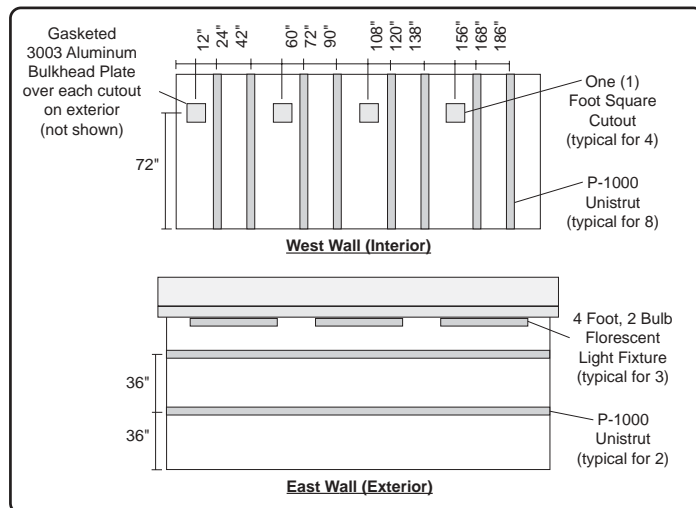

In the second detail, the Client has specified the placement of three lighting fixtures and two horizontal mounting rails. However, as you can see, no dimensions are specified for the fixtures. An inquiry determined that the Client intends to locate 4 sample systems on the wall, and wants them to be illuminated. The best locations for the fixtures was mutually determined to be one foot from the outer edge of the eave, evenly distributed along the length of the building.

Since equipment of substantial weight will be mounted on the East and West walls, Bebcos elected to upgrade framing members from 18 to 12 Gauge Steel, ensuring sufficient support for the mounting rails. Finally, rib frame members of the West wall were positioned to align with the mounting rails, to provide critical support and avoid the areas reserved for cutouts.

Type IDFS Shelter Accessories

Shelter Bases

Materials: Painted Steel, Galvanized Steel, Aluminum & Stainless Steel
Styles: Open, Grated, Sump & Deck

Shelter Doors

Materials: Fiberglass, Galvanized Steel, Aluminum & Stainless Steel
Standard Sizes: 2', 3' & 4' W x 7', 8', 9' & 10' H (*Custom Sizes Available*)
Styles: Single or Double, w/ Full Hardware & Windows, as Required
Frame: Integrated Into Fiberglass Shelter Wall System
Custom Features: Removable Transoms, Door Operators, Air Curtains

HVAC Units & Pressurization Systems

(Request **Bebco Environmental Control Units Division Literature**)

Standard Types: Wall, Roof & Remote (pad) Mount
Suitability: UL Listed General Purpose & Hazardous (Classified) Areas

Interior & Exterior Lighting Systems

Standard Types: Incandescent or Fluorescent
Suitability: UL Listed General Purpose & Hazardous (Classified) Areas

Equipment Packaging Services

Power: Disconnects, Shunt-Trips, Breakers, Switches & Receptacles
Safety: Fire Alarm, Fire Suppression, Gas Detection & Ventilation Units
Wiring: General Purpose EMT & Hazardous (Classified) Area Conduit
Pneumatic: Process Compression Tubing and Pipe (threaded or welded)
Equipment: Racks, Cable Tray, Enclosures, Cabinets & Lab Bench Tops
Instrumentation: Analytical, Process, Laboratory & Control Systems

Single Pane Fixed & Operating Windows

Single Pane Standard Sizes: 1' - 6' wide x 1' - 3' high in H Type Gasket
Single Hung (1 over 1) Standard Sizes: 2' & 3' wide x 2', 3', 4' & 5' high
Horizontal Sliding Standard Sizes: 3' high x 3', 4', 5' & 6' wide
Styles: 1/8" or 1/4" Laminated Safety Glass, w/ or w/o Wire Reinforcement
Operating Window Frames: Anodized Aluminum w/ Latch & Screen

Wall Bulkheads

Materials: Galvanized Steel, 3003 Aluminum & 304 or 316 Stainless Steel
Standard Sizes & Styles: 12" wide, 12", 24" 36", 48" & 60" high
Attachment: Exterior Flat Plate or Concealed Interior Recessed Pan
Styles: Bolt Fastened Blank or Pre-Punched

Flooring

(Applicable only for Shelters furnished with Deck Base)

Paint: Plain or Slip Resistant Polyurethane
Vinyl Laminate or Tile: 1/8" & 1/4" **Color & Pattern:** As Specified
Access (Raised) Flooring: 250-500 lbs/sq ft & Custom up to 2500 lbs/sq ft
Style: 2" Square Tiles **Elevations:** 2"-36" **Color & Pattern:** As Specified

Suspended Ceilings Systems

Style: 2 sq ft Tiles & Full Grid Framing **Color & Pattern:** As Specified

Awnings

Materials: Galvanized Steel, 3003 Aluminum & 304 or 316 Stainless Steel
Standard Sizes: 24", 36" & 48" Wide w/ Drip Ledge
Styles: Partial, Full Length or Wrap-Around
Attachment: Permanent or Removable

Equipment Platforms

Standard Capacities: 250 - 2500 lbs/sq ft
Materials: Galvanized Steel, 3003 Aluminum, 304 or 316 Stainless Steel
Styles: Level or Elevated, Solid or Grating, Permanent or Bolt Fastened

Mounting Strut

Weight Load Capacity: Horizontal 8'-12' - 400 lbs, Vertical 8'-12' - 2500 lbs
Materials: Galvanized Steel, 3003 Aluminum & 304 or 316 Stainless Steel
Placement: Interior & Exterior, Permanent or Removable

Gutters & Downspouts

Materials: Fiberglass, Galvanized Steel, Aluminum, Stainless Steel
Styles: Seamless & Component Form
Attachment: Permanent or Removable

Custom Paint Finishes

Materials: Polyurethane, Epoxy or Enamel
Color: As Specified **Thickness:** 3-6 Mil. As Specified

IMPORTANT NOTES

All specifications subject to change without notice.
Warranty & Liability policies available upon request.
Resin, Gel Coating & Insulation MSDS Available Upon Request

Model Number Designations

Example: IDFS-D-08-10-20-T-04-LEG-02-06

Series _____
IDFS - Industrial Duty
Fiberglass Shelter

Grade _____
S - Standard Grade
D - Deluxe Grade

Ceiling Height _____
XX - 08-12 Feet, Standard

Width _____
XX - 06-14 Feet (Single Wide)
- 16-28 Feet (Double Wide)

Length _____
XX - 06-50 Feet

Configuration _____
B - Bottom Lift
T - Top Lift

Wall Thickness _____
03 - 03 Inches (R-15.9)
04 - 04 Inches (R-21.2)
06 - 06 Inches (R-31.8)
09 - 09 Inches (R-47.7)
12 - 12 Inches (R-63.6)

**Substitute
Number to
Obtain Any
Thickness**

Roof Style _____
LEG - Low Eave Gable
LFG - Low Flush Gable
HEG - High Eave Gable
HFG - High Flush Gable
ES - Eave Shed
FS - Flush Shed
EF - Eave Flat
FF - Flush Flat

**Bebco Industrial Duty
Fiberglass Shelters
normally feature a white
gel coat finish, but are also
available in other colors.
Please contact Bebcos
for more information.**

Door Opening(s) _____
XX - Specify Quantity

Wall Cutout(s) _____
XX - Specify Quantity

IMPORTANT NOTES

Custom Height, Width & Length Available Upon Request

Client must furnish placement diagram(s) to specify location of door opening(s) and wall or roof cutout(s) - see Page 7

Width & Length specify exterior dimensions of Shelter

Height specifies interior (ceiling) dimension of Shelter

Overall Height of Shelter dependent on Roof Style

R-Value of 5.3/inch calculated @75°F (see Specification 1.4)

Complete Shelter requires utilization of Bebcos Shelter Door(s) and Bebcos Shelter Base. Exception: Top Lift Configuration Shelters are suitable for placement on slab or other stable surface without Base.

Single Wide Shelter configurations shipped as one (1) piece

Double Wide Shelter Configurations shipped as two (2) pieces

Local Sales Representative

KGA Engineering Company, Inc.
Bebco Midwest Representative
847.367.5700
www.kgaeng.com